

# DESIGN AND EVALUATION OF THE DETECTION SYSTEM FOR UNIFORM DRESSING/UNDRESSING USING INTRA-BODY COMMUNICATION TECHNOLOGY

M. FUJIKAWA<sup>1,5</sup>, M. NISHIGAKI<sup>2</sup>, M. YOSHIZAWA<sup>3</sup>, K. FURUSAWA<sup>4</sup> & S. TSUJII<sup>5</sup>

<sup>1</sup>Sohgo Security Services Co., Ltd. (ALSOK), Japan.

<sup>2</sup>Shizuoka University, Japan.

<sup>3</sup>Tokyo Metropolitan College of Industrial Technology, Japan.

<sup>4</sup>Mitsuya Laboratories Inc., Japan.

<sup>5</sup>R&D Initiative, Chuo University, Japan.

## ABSTRACT

The authors developed a new uniform dressing/undressing detection system. This system utilizes intra-body communication technology in the form of a sensor to detect whether the uniform is worn or not. Problems associated with conventional uniform dressing/undressing detection systems using ultrasonic sensors are eliminated owing to the use of intra-body communication technology. High practicality, reliability, and safety of the proposed system were demonstrated by installing and experimenting the system in an actual uniform.

*Keywords: Abuse of uniforms, intra-body communication, social engineering.*

## 1 INTRODUCTION

Crimes such as swindling money and valuables from people by posing as officials wearing illegally obtained occupational uniforms or imitations of genuine uniforms are frequent everywhere in the world and at all times [1, 2]. This is a crime effectively utilizing the assumption that those in official uniforms are genuine officials; in the study on security, it is called “social engineering” [3].

In the military field, the Identification Friend or For (IFF) system (see Fig. 1) of quickly identifying whether specific approaching aircraft, aiming aircraft or vessels is friend or foe is a well-established technology [4]. In this system, an interrogating signal is transmitted to the approaching aircraft requesting a response signal. If the received response signal is correct, the system determines that the approaching aircraft is a friend, and if the response signal is incorrect or no signal is received, the system determines that the approaching aircraft is hostile. For example as shown in Fig. 2, when such a system is incorporated into a police officer’s uniform and a door phone system is used, the person inside the house may be able to identify whether the visitor is a genuine police officer or not.

Prerequisites: A door phone system should be connected to a secure network with constant access to information about the police officer’s uniform. The system should be able to determine the authenticity of the person ringing the bell wearing a police officer’s uniform and to notify the person in the house of the authentication. No person other than a police officer will have the uniform.

With such a system, it is possible to cope with social engineering when someone uses a uniform imitating an occupational uniform; however, because of social engineering, someone using a genuine uniform cannot be recognized as impersonating an official. Considering that genuine uniforms are sold via Internet auction sites [5], social engineering may occur when

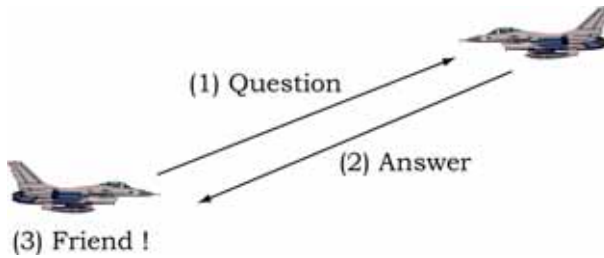

Figure 1: Image diagram of the IFF system.

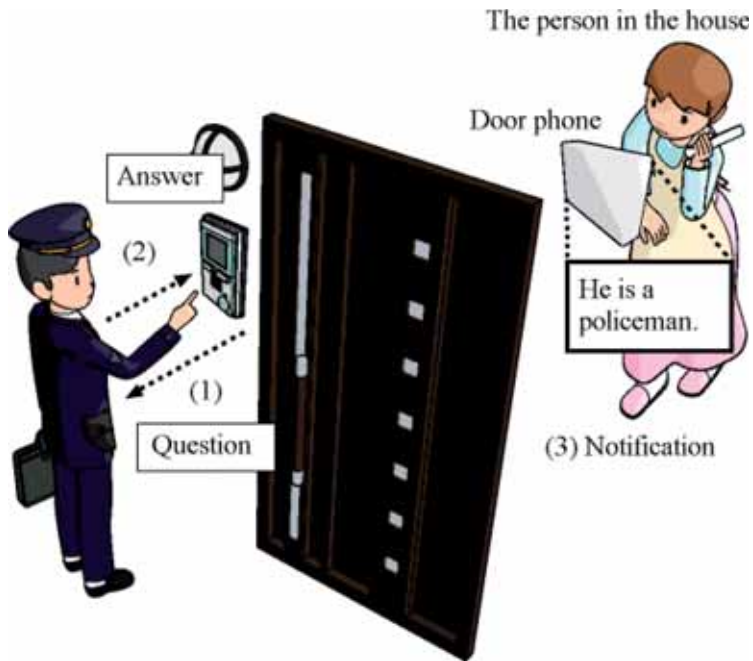

Figure 2: Incorporation into the Door Phone System.

someone uses the genuine occupational uniform. Accordingly the authors consider it necessary to develop a system with the following functions.

1. Uniform “A” can recognize whether a person wearing Uniform “A” is genuinely Employee “A”.
2. Uniform “A” activates a function demonstrating that Employee “A” is genuinely Employee “A” as long as he/she is wearing Uniform “A”.
3. Anyone can easily recognize whether an employee wearing a uniform is the genuine employee.

The authors started the study on the uniform dressing/undressing detection system that will become the basis of such system and developed a system using an ultrasonic sensor [6]. However, there were some flaws in the developed system, for example, what if the uniform worn cannot be recognized. So in this paper, a new uniform dressing/undressing detection system

is proposed. Intra-body communication technology is employed in this new system where a sensor detects whether the uniform worn is genuine or not. Experiments conducted to verify the practicality, reliability, and safety of the system and discussions on the results of experiments are included in the latter part of this paper.

## 2 PROPOSED SYSTEM

### 2.1 Intra-body communication technology

Intra-body communication technology was developed as a communication technology using human body as communication path based on its ability to hold a static charge and to conduct a slight electric current. Among several methods so far proposed [7, 8, 9], the static coupling method is used in this study (see Appendix). The reasons for using the static coupling method are as follows.

1. Electrodes are not necessarily in contact with the human body.
2. Communication can be established even when the electrodes are covered with a thin layer of insulation material.
3. Experiments are possible with the simple configuration of equipment, and inexpensive installation of the detection devices.

### 2.2 Detection mechanism of dressing/undressing

In this section, the mechanism of detecting dressing/undressing is explained. First, the method of installation of the dressing/undressing mechanism is explained (see Fig. 3) and then the functions of the detector are provided.

The detector, the transmitting electrode, and the receiving electrode are connected to a shielded wire, and each electrode is installed on each side of the shoulders of the upper



Figure 3: Installation of dressing/undressing detection system.

garment. This is because experiments have shown that both shoulders are always in contact with the upper part of the garment of the worn uniform (whether half sleeves or long sleeves). The detector sends a signal to the transmitting electrode by applying a slight alternating current. The detector amplifies the received signal with the receiving electrode and compares it with the transmitted signal and determines whether both signals match.

Next, the mechanism of detecting the dressing/undressing of the upper garment is explained. When the upper garment is worn, the electrodes and shoulders are closer and a signal loop consisting of detector → shielded wire → transmitting electrode → human body → receiving electrode → shielded wire → detector is formed. Thus, the detector will receive a signal transmitted by the detector itself. However, if the upper garment is taken off while a signal is transmitted and received, the electrodes pull away from the shoulders and the signal loop is broken, and the detector is unable to receive the transmitted signal.

As explained above, it is possible to determine that the upper garment has been worn when the transmission/receiving of the signal is established and that when the upper garment is not worn there is no transmission/receiving of the signal. Thus, the detector and two electrodes can be used as a dressing/undressing detection system of the upper garment. In this section, the upper garment system was explained, but dressing/undressing detection of the lower garment is also possible if the detector and electrodes are installed in the lower garment.

### 3 IMPLEMENTATION

After the feasibility of the proposed system was confirmed with the basic experiment [10], the authors installed the system on an actual uniform. Figure 4 shows the system configuration, Fig. 5 shows the detector circuit board, and Fig. 6 shows how the system is installed in a uniform shirt.

Specifications of the system are as follows.

1. Uniform used fits the shape of the tester for the experiments.
2. Power supply used is a 006P 9 V dry cell.

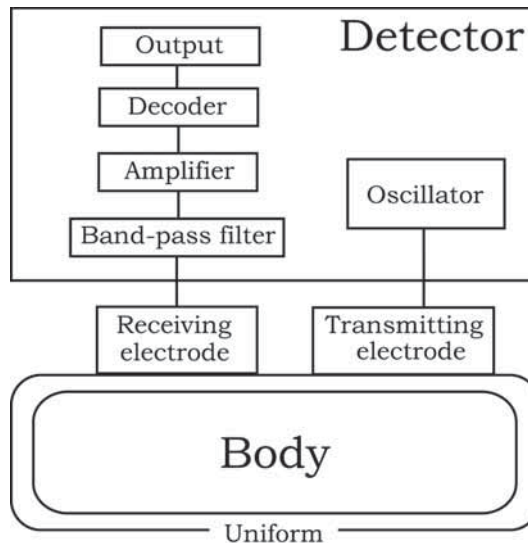

Figure 4: System configuration diagram.

3. Electrodes are made of copper foil with its surface covered by a PVC sheet and a cloth patch and is attached to the back of the uniform (at the shoulder) with hook-and-loop fasteners.
4. The oscillator generates and transmits 100 kHz signals to the transmitting electrode.
5. Signals received by the receiving electrode are sent to the decoder through the band-pass filter and amplifier.
6. At the decoder, the transmitted and received signals are compared, and when both signals match, the decoder determines that the intra-body communication is established (i.e. the uniform is put on) and illuminates LEDs labeled “Receiving” and “Decoding.”

On interruption of intra-body communication for 5 seconds, the decoder recognizes that there is no uniform and switches off the “Receiving” and “Decoding” LEDs and switches on the LED labeled “Undressing.”

When the intra-body communication is re-established, the decoder switches off the “Undressing” LED and switches on the “Receiving” and “Decoding” LEDs.

When dressing and undressing of the uniform was repeated by the tester, wearing an undershirt for the experiment, the system functioned according to the specifications. With this system installed in the jacket of the uniform, dressing and undressing with the jacket was repeated by the tester, who was already wearing an undershirt and a dress shirt; the system still functioned according to the design.

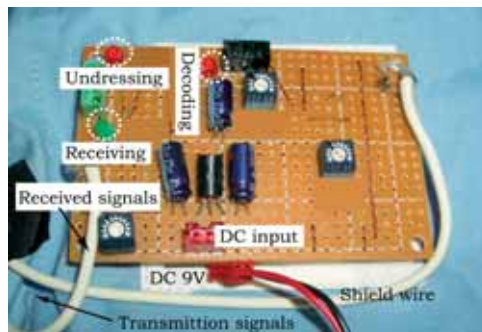

Figure 5: The detector circuit board.

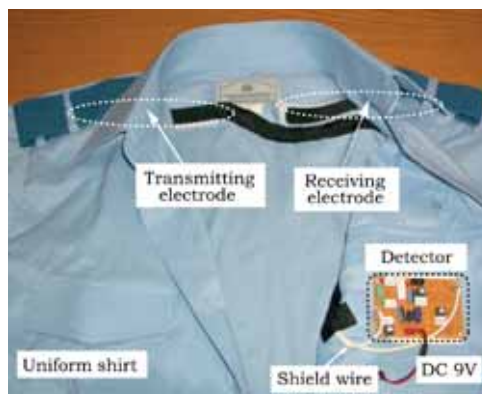

Figure 6: System setup in a uniform.

It was also tested while the uniform was worn and repeating (1) the up/down movement of the arms, (2) hopping, and (3) jogging on the spot, and the system functioned accordingly. All these results show that the proposed system is highly practical and reliable.

## 4 CONSIDERATIONS

### 4.1 Superiority of proposed system

This section shows that the problems associated with the dressing/undressing detection system using ultrasonic sensor [6] are eliminated in the proposed system.

First, the mechanism of the system using an ultrasonic sensor is explained. As shown in Fig. 7, the Transmitter, Receiver A, and Receiver B are installed on the back of the upper garment so that Receiver A and Receiver B face each other. The transmitter generates intermittent ultrasonic waves in a semispherical direction.

As shown in Fig. 7 (A), Receiver B does not receive ultrasonic waves from the transmitter when the jacket is worn. This is because ultrasonic waves are reflected by the skin without penetrating into the body, due to the difference in acoustic impedance between the air and the human body. Conversely, when the jacket is taken off, as shown in Fig. 7 (B), the Receiver B will receive ultrasonic waves from the Transmitter. Thus, this system determines whether the uniform is worn or not by identifying whether ultrasonic waves are received or not. However, the following problems are associated with this system.

1. Although the size of the transmitter and receiver is small, they are thick, and exert pressure on the body causing pain and discomfort to the person wearing the upper garment because of the external pressure on the upper garment.
2. If the Transmitter B fails and cannot receive ultrasonic waves, while the uniform is worn, the system cannot identify whether the system failed (i.e., the system cannot detect that the uniform is taken off).
3. False undressing method: If a tube that is opaque to ultrasonic waves is placed between the body and the uniform, when the upper garment is worn, and the upper garment and the tube are taken off at the same time, the system will not recognize the removal of the uniform because the Receiver B cannot receive ultrasonic waves.

In the proposed system, these problems are eliminated as follows.

1. The electrodes are thin and flexible and do not cause any discomfort or pain from pressure on the human body applied from outside the upper garment.

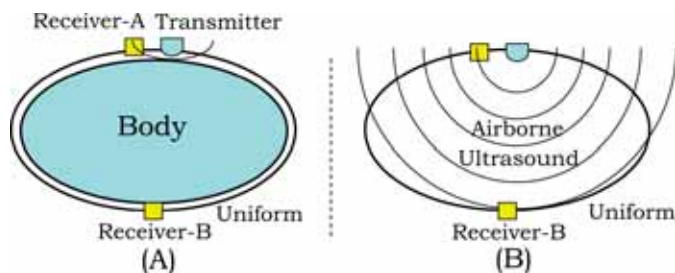

Figure 7: Dressing/undressing detection method using an ultrasonic sensor.

2. If either of the electrodes fail, while the uniform is on, transmission/receiving of the signal is interrupted, and the system determines that the uniform has been removed. The system can notify the user of a failure through a buzzer or a vibrator.
3. If the uniform and the tube are removed from the human body simultaneously, the signal loop is broken and transmission and receiving of the signal are interrupted. Thus, the system will recognize that the uniform has been removed.

As explained above, the proposed system eliminates the problems of the system using an ultrasonic sensor.

#### 4.2 Safety of the proposed system

In the proposed system, high frequency signals are fed to the human body but no electrical shock is associated with those signals. Within the industrial and medical worlds, the following criteria implemented to avoid electrical shock.

**Voltage:** According to IEC 60950-1 (Information technology equipment – Safety – Part 1: General requirements), it is specifically provided that peak voltage is less than or equal to 42.4 V or DC voltage less than or equal to 60 V is called the safety extra-low voltage (SELV) and is not harmful to the human body.

**Current:** According to JIS T0601-1 (Medical electrical equipment – Part 1: General requirements for safety), it is specifically provided that electrical current which is less than or equal to 0.05 mA is not harmful to the human body.

The reason one do not experience an electrical shock when using a body fat meter or a body composition meter is because these products employ voltage and current within the above mentioned criteria. Furthermore, the human body is susceptible to electrical shock with low frequency current but not susceptible to high frequency current.

1. Electric cautery uses a maximum of 1 A of electric current to the body, but the patient does not experience an electric shock because the high frequency current in the range of hundreds of kilohertz to several megahertz is applied to the body part [11].
2. The reason a person who uses a low frequency therapy device feels pain is because the device uses low frequency current of less than 1 kHz [12].

In the proposed system, current, voltage, and frequency are in accordance with the above criteria, and the person wearing the uniform will not experience any electrical shock.

#### 4.3 Use of the conductive fabric

In the actual installation, the surface of the copper foil is covered with PVC film and a patch of fabric. This is also necessary to prevent metal allergies (inflammation of the skin close to the electrode due to the chemical reaction between chloride ions in sweat and copper). In practical application, a conductive cloth is used for the electrodes so that a person wearing the uniform will not feel the electrodes installed in the uniform. Description of the method is as follows.

##### 4.3.1 Use of the silver fiber

A patch of cloth woven from a string coated with silver [13] is used as an electrode. Silver has excellent conductivity and causes no harm to the human body; the material is used in tableware and artificial teeth.

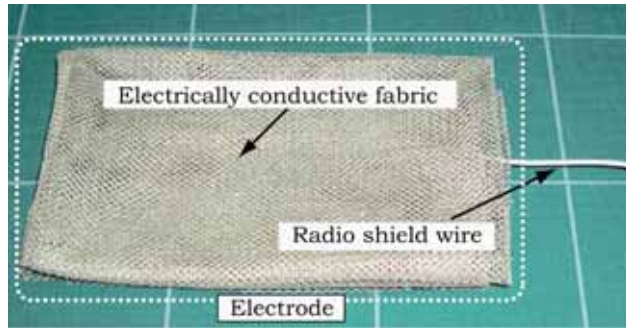

Figure 8: Electrode made of silver mesh fabric.

#### 4.3.2 Method of installation

As shown in Fig. 8, the edge of the conductive fabric patch and one end of the shield wire are insulated, and the patch is sewn on the back of the upper garment (at the shoulders).

### 5 CONCLUSIONS

Dressing/undressing detection system using intra-body communication technology that enables detection of dressing/undressing of the uniform was engineered and proposed. The system was installed in an actual uniform and practicality and its high reliability were demonstrated, and the superiority and safety of the proposed system were explained. It is intended to further improve the system for practical application.

### ACKNOWLEDGEMENT

A part of this study was supported by the Nippon Uniform Canter.

### REFERENCES

- [1] Bell, R., Outrunning the law, available at [http://www.trutv.com/library/crime/criminal\\_mind/scams/frank\\_abagnale/](http://www.trutv.com/library/crime/criminal_mind/scams/frank_abagnale/)
- [2] The Washington Post, Alleged Fake Cop Had 'Police Station', available at <http://www.washingtonpost.com/wp-dyn/content/article/2007/02/10/AR2007021000288.html>
- [3] Mitnick, K., Simon, W.L. & Wozniak, S., *The Art of Deception: Controlling the Human Element of Security*, John Wiley & Sons: Hoboken, NJ, USA, 2002.
- [4] Global Security.org, Identification Friend or For (IFF) System, available at <http://www.globalsecurity.org/military/systems/aircraft/systems/iff.htm>
- [5] NEWS.SCOTSMAN.COM: Officer sacked for selling helmet, Published Date: 17 May 2008, available at <http://news.scotsman.com/aberdeen/Officer-sacked-for-selling-helmet.4094052.jp>
- [6] Fujikawa, M., Aoki, H., Nishigaki, M., Yoshizawa, M. & Tsujii, S., Design of office security system that is capable of detecting unauthorized persons wearing office uniforms. *Proc. of the 2nd Int'l Conf. on Safety and Security Systems in Europe*, 2007.
- [7] Doi, K. & Nishimura, T., Technologies for personal fitness: High-Reliability communication technology using human body as transmission medium, MEW technical report (Japanese Text), available at <http://sciencelinks.jp/j-east/article/200519/000020051905A0765593.php>
- [8] Nippon Telegraph and Telephone Corporation (NTT), What's Red Tacton?, available at <http://www.redtacton.com/en/info/index.html>



- [9] Kato, Y., Akioka, S. & Mitsubayashi, K., Heart rate Measurement by Ubiquitous Human body Communication, available at <http://scielinks.jp/j-east/article/200603/000020060305A0916340.php> (Japanese Text)
- [10] Fujikawa, M., Nishigaki, M., Yoshizawa, M., Furusawa, K. & Tsujii, S., Proposal of uniform dressing/undressing detection system using body-based data transmission technology – To prevent a crime abusing office uniforms -. *Proc. of the Domestic Symposium on Computer Security*, pp. 701–706, 2008.
- [11] Medical & biological system, Lecture Note (Vol.11), Biological properties and Safety, available at [www.t-net.ne.jp/~kondoy/lecture/bme/11.pdf](http://www.t-net.ne.jp/~kondoy/lecture/bme/11.pdf) (Japanese Text)
- [12] NIHON MEDIX, Low-frequency massage device (Japanese Text), available at [http://www.nihonmedix.co.jp/page/reha/reha\\_page01-02.html](http://www.nihonmedix.co.jp/page/reha/reha_page01-02.html)
- [13] Less EMF Inc.: High performance silver mesh fabric, available at <http://www.lessemf.com/fabric.html>

This paper has been selected for this special issue but first appeared in WIT Transactions on the Built Environment, Vol 108, © 2009 WIT Press, [www.witpress.com](http://www.witpress.com), ISSN 1743-3509 (on-line), doi:10.2495/SAFE090201.

#### APPENDIX

The basic concept of intra-body communication is the same as the concept of wired communication. Generally, two conductive lines are required for wired communication. i.e., one is used as a signal line that transmits and receives the signal, and the other is used as a reference line to translate the reference potential. It is impossible to use the human body to act as two conductive lines because it is a single conductor, and only one conductive line is possible. So in the static coupling method (see Fig. 9), the human body is used as a signal line and static coupling is used as the reference line. Static coupling is the state where a capacitor equivalent is formed between the reference electrode and the space, and it provides the function as a conductive line for alternating signal, although it is not a visible conductor.

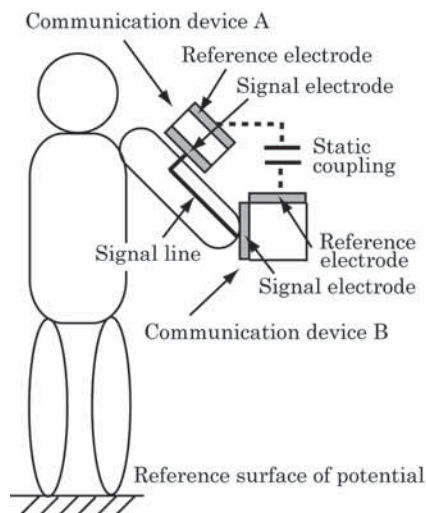

Figure 9: Diagram of the intra-body communication technology by using the static coupling method.