

LEVERAGING INFORMATION FOR HIGH LEVEL-OF-ABSTRACTION ORGANIZATIONAL PROCESSES

J.L. DALMAU-ESPERT, F. LLORENS-LARGO, P. COMPAÑ-ROSIQUE, R. SATORRE-CUERDA & R. MOLINA-CARMONA.

Department of Computer Science and Artificial Intelligence, University of Alicante, Spain.

ABSTRACT

Nowadays, Big Data techniques have made possible to obtain interesting low-level information from large amounts of data. However, the information is often difficult to be enriched enough to aid in high-level organizational processes. The objective of this work is to define a model to allow the use of available information for the design and implementation of high level-of-abstraction processes that take place in the organizations. Particularly, this paper is focused on the strategic planning (SP) process, one of the most complex and abstract processes in any company. So far, there are very few successful attempts to automate this process, which is usually based on manual tasks. At the most, the results from the automatic data analysis are generated and used as reports and are not integrated in the process. A further step is proposed, posing a SP model based on a multi-agent system with a blackboard, which is used as a means of communication and storage of the generated information. The information is described using ontology to formalize both the SP process and the information used in each step. The combination of these elements enables the participation, interaction and sharing of information and knowledge of the participants in the process. The accumulated knowledge allows the use of previous experience to automate the process and improve the decision making. In short, the proposed model is a formal, comprehensive, agile and flexible solution to perform the process of SP in organizations today leveraging of the enormous amount of available data and the gathered experience.

Keywords: multi-agent system, ontology, organizational process, strategic planning.

1 INTRODUCTION

Present organizations develop and interact in an environment that is characterized by high uncertainty and great complexity, caused by the internationalization of the companies, globalization of the economy and the high technological dynamism. These events cause the growing importance of information and knowledge, in the so-called intelligent organizations [1].

The change in the organizational model implies a need for a review of traditional business processes, particularly the most abstract management processes. One of the main management processes is the strategic planning (SP) process. It is defined as the process in which the managers of an organization analyse the internal and external environment of the organization to develop strategies and allocate resources to gain a competitive advantage in the industry so that the objectives of the organization could be successfully achieved [2]. The SP process is the base to make informed decisions in the organization.

The need to support strategic decision making has led to the development of techniques and technologies focused on the proper treatment of information. Particularly, there have been many advances in the way that big data techniques face their challenges: the huge and growing volume of data, the need to short response time, the heterogeneous data and data sources, or the efficient analysis methods. Today, it is possible to get interesting answers from the data but usually the analysis



This paper is part of the Proceedings of the International Conference on Big Data (Big Data 2016)
www.witconferences.com

stays in a low level of abstraction, that is, there is no automatic way to raise low-level information to a higher level to obtain new knowledge that will help in complex organizational processes. In fact, even today many high-level processes related to decision making are manually made because the available information is often in the form of reports and pre-set data.

The objective of this paper is to define a model to allow the use of available information for the design and implementation of high level-of-abstraction organizational processes. The main contributions are: the formalization of the participation of the stakeholders involved in the process; the definition of a framework for integrating all kinds of information sources, techniques and technologies for information and knowledge collection, management and dissemination; and the storage and reuse of the information and tools to create new knowledge and intelligence and to reach certain automation. Specifically, as an attempt to shed light on this issue, we will focus on the SP process, one of the most complex and abstract processes in any company.

This paper is organized as follows: section 2 presents the background of the proposal; section 3 describes the proposed model, ontology and a multi-agent system (MAS) to design and implement it; and section 4 presents the conclusions.

2 BACKGROUND

2.1 Intelligent organizations

Information, knowledge and learning are the main assets of the new model of intelligent organization, and it has now become the best way to compete [3]. Information is the external stimulation obtained by the organization, causing a change in its continuing action [4]. Knowledge can be defined as the information actionable by the organization, obtained by integrating experienced events, learned from others, or created by it [1]. Learning is the process by which the knowledge created by individuals is amplified and crystallizes as part of the knowledge system of the organization [5]. There are many works focused on the organizational information, knowledge and learning management, particularly through the use of the information and collaboration technologies.

Relating to techniques and technologies for information collection, management and dissemination, Riaño *et al.* [6] describe an ontology-based web search system to ease the enterprise managers in the process of discovering new knowledge from Internet documents. Howson [7] introduces business intelligence and big data as technologies for collecting information and extracting knowledge. Prescott and Miller [8] define collective intelligence technologies and enumerate strategies for using them and collecting competitive information within the organizations. Ferrara *et al.* [9] make a survey about the techniques for extracting information from specific sources, concluding that these techniques are domain-dependent and specifically designed for the existing problem and the information source type. Baumgartner *et al.* [10] present a solution for the online market intelligence problem based on a novel web data extraction technology. Sánchez Torres and Palop [11] find a common feature in these technologies: the information is generally presented in reports that are disseminated and, then, considered as the input of knowledge creation process.

Maruta [4] introduces definitions, a thinking model for knowledge acquisition and creation and a classification of knowledge workers based on their capacity to acquire knowledge. Bittner and Leimeister [12] apply collaboration engineering to derive a validated collaboration process module to systematically support heterogeneous work groups in building shared understanding.

There are also many articles about the benefits of organizational learning, information and knowledge use/reuse and its application within the organizations for improving their competitiveness and

decision making. As an instance, Monticolo *et al.* [3] explain how six different types of knowledge are capitalized in project memories and used/reused to solve problems or assist actors during engineering projects.

2.2 Attempts to automate the strategic planning process

SP is the organizational process of developing and maintaining a strategic management, given by the Mission, the Vision and an internal/external analysis, so that the objectives and resources of the organization can be aligned with the changing business opportunities [13]. Hill and Jones [14] contributed with a list of concept definitions and techniques related to this process. Beyond the SP definition, there are some works that propose novel systems for carrying it out and for planning and managing general strategic information. From the literature review, it can be concluded that it is generally agreed the suitability of the MAS and ontologies for facing this kind of process and information management. On one hand, an MAS is a set of interacting intelligent agents within an environment that, beyond the individual objectives of each agent, pursue a common goal as a whole [15]. An MAS is suitable when the nature of the problem is complex and uncertain. There are heterogeneous and distributed information sources, and the solution may be achieved in various stages through the mutual cooperation among agents, which contain the logic and the knowledge. On the other hand, ontology is a formal, explicit specification of a shared conceptualization [16]. Within SP process approaches, participants are viewed as agents responsible for creating the content of the strategic plan while the ontologies are used for creating the shared understanding and vocabulary that agents use to communicate among them.

Orwig *et al.* [17] propose MAS that contains a method to reach the convergence and consensus about the strategic content. Pinson *et al.* [18] describe a blackboard-based architecture [19], a task decomposition of the SP process into a number of modules (agents) with different knowledge levels and goals and a mechanism to enable the cooperation and negotiation among these agents. Liu *et al.* [20] show the flexibility of MAS to deal with internal/external environment uncertainty and its knowledge and to handle planning changes.

Paradies *et al.* [21] analyse how ontology structures can be used for strategy content management and process modelling. Paradies [22] also introduces an approach to support SP by ontological structures that enable the organization and management of the strategic knowledge and information. This approach provides an abstract editable representation of strategy content,

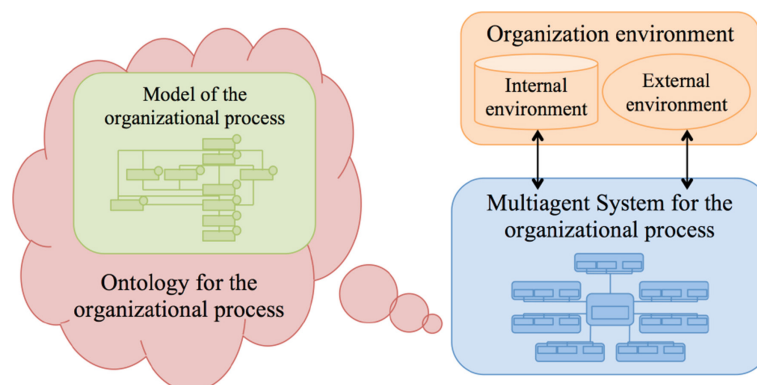

Figure 1: Elements of the proposed model.

and it assumes that the SP process could not be automated. Aguilar *et al.* [23] explain the feasibility of the MAS features within the enterprise planning process. Finally, Monticolo *et al.* [3] describe how ontologies and MAS can be combined to manage heterogeneous and distributed information and knowledge, and establish a cooperative manner to solve problems and use/reuse knowledge.

3 PROPOSAL

In this paper, we propose a system to formalize and automate complex organizational process based on three main elements (Fig. 1):

- Model of the organizational process: it defines the steps of the organizational process to be formalized and automated.
- Ontology for the organizational process: it is the formalization of the organizational process.
- MAS for the organizational process: it is the execution platform that carries out the organizational process from the information taken from the internal and external environments, following the ontology definitions.

The development of a concrete process will lead us to take some specific decisions. In the following sections, we present the particularization of this proposal to carry out the SP process.

3.1 Model of SP process

The model of the organizational process is the basis of all the system. In our particular case, the organizational process to be modelled is the SP process. There are several SP processes described in the literature that would lead to slightly different systems, but they all share the same basic structure. In

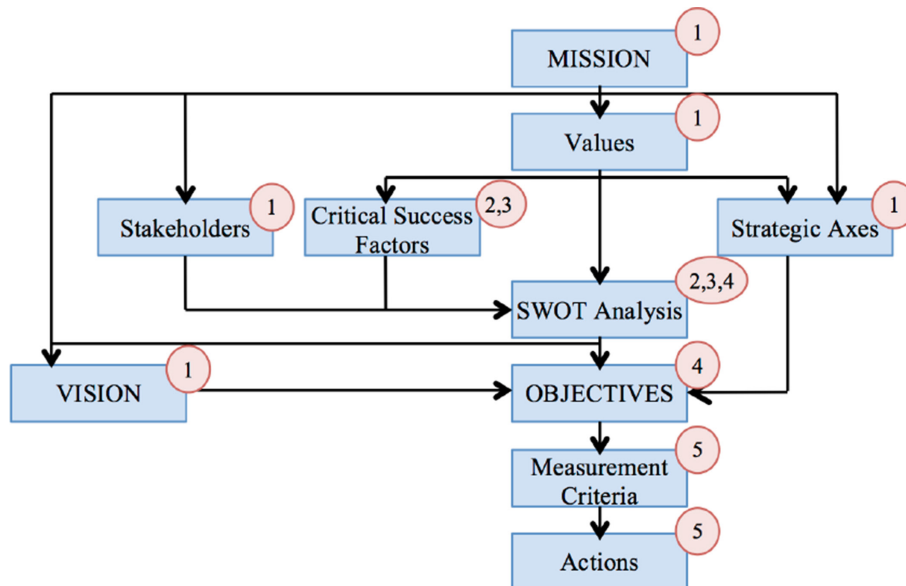

Figure 2: SP model, including the five main steps of Hill and Jones.

this work, the SP process follows the five main steps proposed by Hill and Jones [14] and the SP model stated by Llorens-Largo [24], illustrated in Fig. 2. The general structure of the MAS defined in the following sections can be easily adapted to other SP process models or, even, to other process models.

3.2 Ontology for SP process

An ontology [25] is a formal explicit description of concepts in a domain of discourse (classes or concepts), properties of each concept describing various features and attributes of the concept (slots, roles or properties), and restrictions on slots (facets or role restrictions). An ontology, O_{SP} [26], is proposed to formally design the SP process (Fig. 3). In the figure, boxes represent concepts and arrows relations.

In O_{SP} the concepts are classified into passive and active concepts. Passive concepts are used to create instances that define facts, information or knowledge, which constitute the shared understanding in the SP process design and in the resulting strategic plan. Active concepts have the expertise to define the passive concepts, that is, they are used to create instances that represent the stakeholders who have the expertise and logic to participate in the process and create the information/knowledge stored in the passive concept instances. In Fig. 3, the active concepts contain the word “agent” in their concept name.

The relations among passive concept instances describe dependences in which one instance requires the information of the other to be defined or obtained. They also establish the order to create the instances. On the contrary, a relation between a passive concept instance and an active concept instance reveals that the latter provides the logic to create (indeed it does it) the first one.

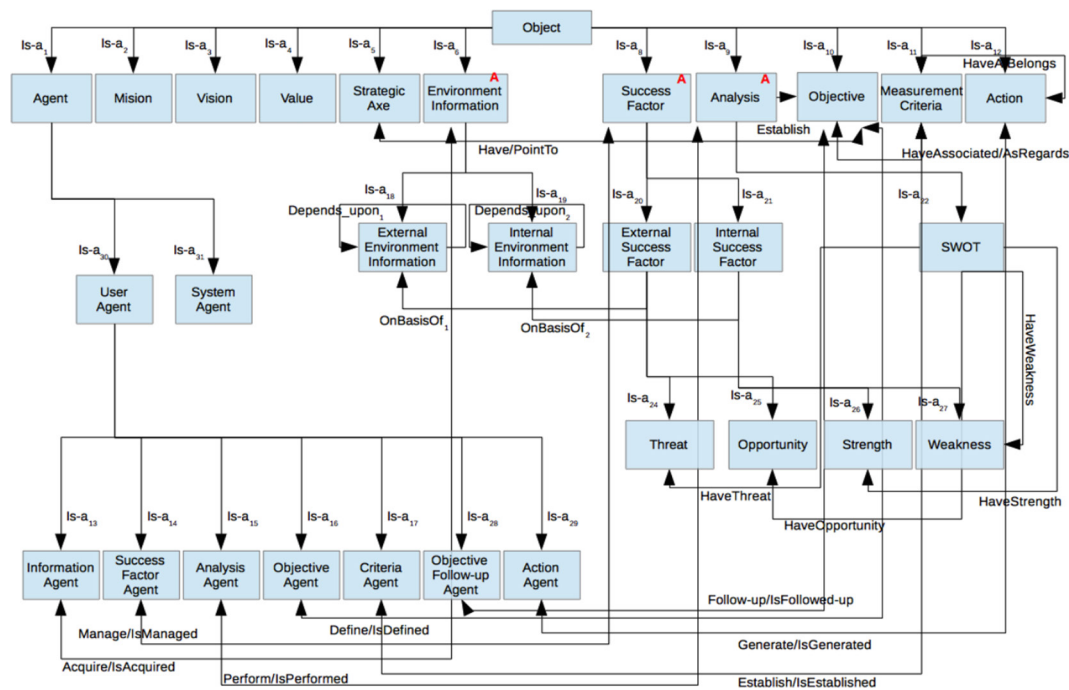

Figure 3: SP ontology.

For communication purpose, the passive concept instances constitute a formal vocabulary that agents can use to communicate among them. Besides, for organization purpose, they represent a unique point of view to see and understand the organization environment.

There are several advantages in the proposed ontology comparing to the way today organizations perform the SP process. O_{SP} directly integrates the setting information and knowledge diversity within the SP process. So there is no need to use several tools depending on information type or source as today companies do. In addition, concept instances definitions can be reused for subsequent SP processes. Finally the ontology itself provides some level of automation.

3.3 Multi-agent System for SP process

The definition of O_{SP} allows the development of a MAS for SP process, SMAPE [27] (from Spanish *Sistema MultiAgente para la Planificación Estratégica*). So, SMAPE is an execution platform based on MAS technology and blackboard architecture to carry out the SP process. This platform controls the process steps execution and the communication and coordination among the participants (modelled as agents) that are involved in each step task.

3.3.1 SMAPE architecture

The SMAPE architecture (Fig. 4) is based on two main elements:

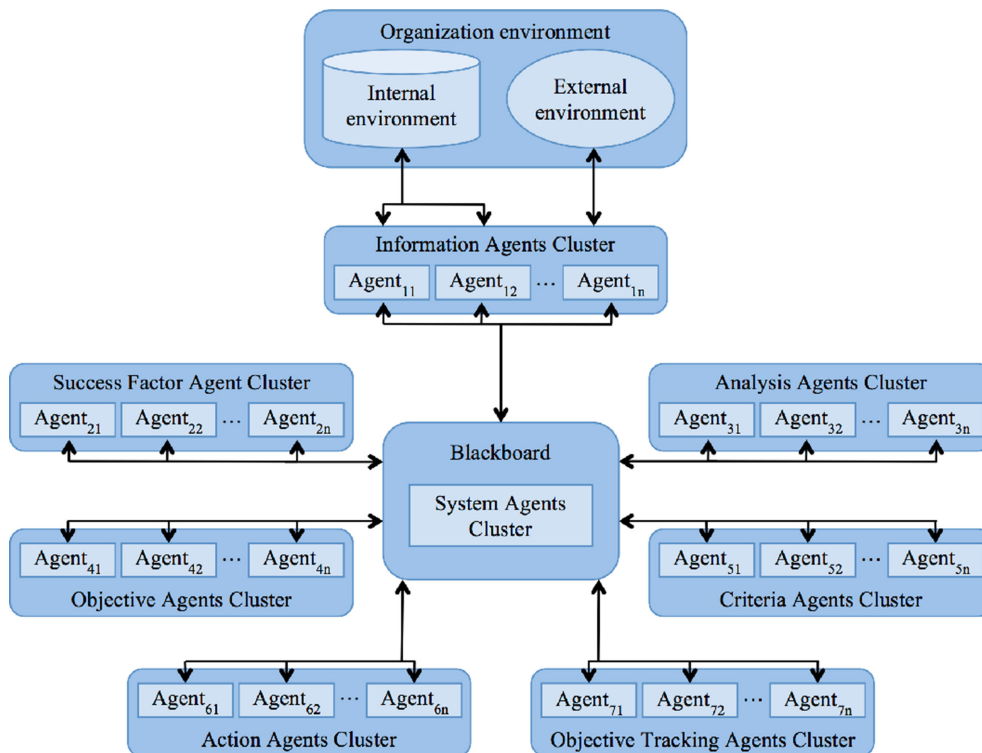

Figure 4: SMAPE architecture.

- Agents: they represent the active concept instances of O_{SP} . They implement the logic to create and manage the information and knowledge (the passive concepts in O_{SP}). In SMAPE, there are user and system agents. User agents carry out specific process tasks, while system agents control the process (agents' coordination, blackboard control, process report generation, and so on). Both system and user agents are grouped in agent clusters that have similar tasks and manage information/knowledge of the same level.
- Blackboard: it is the place to store and share the passive concept instances of the O_{SP} , that is, it is a workspace that agents use to store and exchange information, data and knowledge.

The SP process, using SMAPE, is done in three stages:

- Design stage: from the SP model, the agents in the process are determined, the concepts and relations are identified and the setup parameters are defined. As a result, the MAS is completely defined and ready to be executed.
- Execution stage: SMAPE is executed, so that the agents carry out their tasks, the information is extracted, the new knowledge is generated, and the Strategic Plan of the organization is obtained as a result of the execution.
- Follow-up stage: The strategic plan is implemented in the organization, the actions are carried out, the outcomes of the implementation are collected, the measurement criteria are calculated and all the processes are monitored.

3.3.2 Blackboard

The blackboard has two main functions in SMAPE: it is the public workspace to store and exchange information, data and knowledge and also one of the main ways of communication between agents. The blackboard (Fig. 5) is divided in four layers, corresponding with the three stages defined in the previous section and an additional layer to store historical data: Design Layer, Execution Layer, Follow-up Layer and Historical Layer.

Each layer, in turn, is structured in eight levels. At any layer, each level contains the passive concept instances of the specific SP process steps (defined in Fig. 2) and an additional level (Process

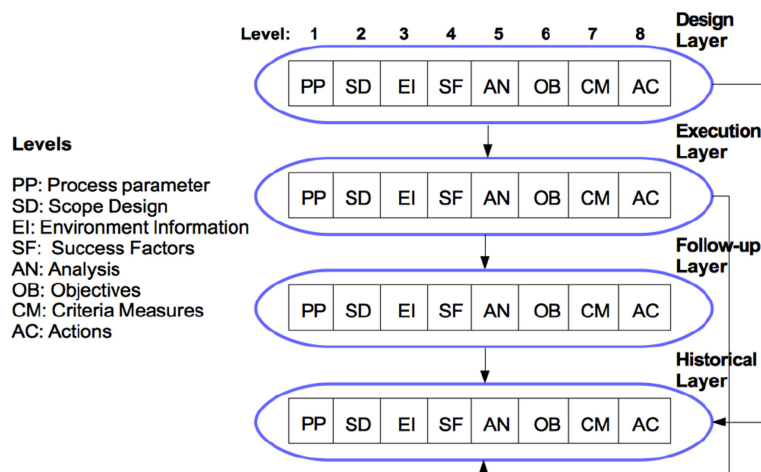

Figure 5: SMAPE blackboard layers and levels.

Parameter level) that contains the process parameters that are necessary for configuring the global process (e.g. number of objectives per strategic axe, number of participants...). The Scope Design level is associated with process step 1, so it contains instances from concepts as mission, vision strategic axes, and so on. The environment information and success factor levels are related to process steps 2 and 3; the analysis and object levels are associated with step 4; and criteria measures and action levels are related to step 5.

3.3.3 System agents

System agents, grouped in the System Agents Cluster, carry out tasks about system and process control. They are automatically activated when the process execution starts, and the communication among them is always through direct messaging. The blackboard control agent (BCA) and the stakeholder agent are the most important agents within the system agents cluster.

The BCA is the brain of the system. It manages the process information and knowledge stored in the blackboard and controls the agent coordination. The BCA is the only agent with a fixed architecture, composed by the following modules (Fig. 6):

- Agent interface: it is the port used for receiving messages (information requests) and sending them (available information confirmations). The agent interface has an agent interface structure for stacking received messages that are managed one by one in a specified order.
- Communication module: its function is to decompose the input messages (extracting sender, receiver and message information) and to compose the output messages when the decision module has finished its task.
- Agents registry: it stores the identifiers of the agents who request their registration in the SMAPE system.
- Requirements agent: when an information request arrives at BCA, it stores the concept instance identifier from the requested information and the agent identifier from the receiver who needs it.
- Tracking module: it implements a monitoring function that controls the changes into the blackboard contents (information creation, modification or deletion). The tracking module reports the changes to the decision module.
- Decision module: it implements the heuristic function, which establishes what agent requirements may be serviced and the order to be serviced. It implements a coordination algorithm that analyses the dependences between passive concepts instances and generates a dependence

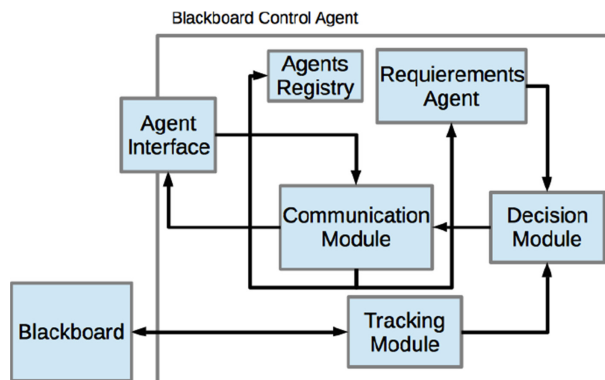

Figure 6: BCA architecture.

tree. This tree sets the order of activation of the user agents and how the requirements are serviced.

The stakeholder agent allows the stakeholder participation within the SP process and the interaction with the other user agents. There are as many stakeholder agents in the system as participating stakeholders in the process.

3.3.4 User agents

The user agents can be of very different nature and implement very different functions but, in order to be able to communicate with the other elements of the system, there are two restrictions to fulfil:

Table 1: Agent logic schema.

1	Send a register message to the BCA and wait for its activation message.
2	Once activated, search for the needed information (passive concept) to carry out the task.
3	If the needed information is not in the blackboard, send a requirement message to the BCA, and wait for its response.
4	Access the blackboard to read the information.
5	Complete the task managing a concept instance (create, modify or delete) existing at the blackboard level that corresponds to the agent cluster level.

- They have to incorporate and implement an agent interface and a communication module in their own architecture, in accordance with the protocol, syntax and semantic of the BCA.
- Its logic has to be implemented following the schema in Table 1.

The user agents are grouped in the following clusters:

- Information agents cluster: group of agents at the lowest level that analyse the environment and extract information from it. This information is represented with instances of external/internal environment concepts, which are stored in the EI level of the execution layer.
- Success factor agents cluster: groups of agents that analyse the information from the lower level and determine what external/internal environment concept instances have information that may be considered as success factors. The agents classify these success factors in strengths, weaknesses, opportunities and threats (SWOT), creating instances of the related concepts in O_{SP} that are stored in the SF level of the execution layer.
- Analysis agents cluster: agent that creates an instance of the SWOT concept (a SWOT matrix) and some other agents (human or not) that complete the matrix values as a result of the SWOT analysis. This information is stored in the AN level of the execution layer.
- Objective agents cluster: agents that determine the objectives to be fulfilled. They are stored in the OB level of the execution layer.
- Criteria agents cluster and action agents cluster: agents that determine, respectively, the measurement criteria and the actions to reach the objectives. They are stored in the CM and AN levels of the execution layer.
- Objective tracking agent cluster: agents that track the objectives of the strategic plan. Unlike other agents, they are activated in the follow-up stage.

The activation of user agents is not automatic: they must be activated when the execution stage starts. There is no restriction about the number of user agents who may belong to each cluster. Each agent may be implemented with the most suitable and reliable internal architecture for its assigned task, with the only restriction of fulfilling the communication rules imposed by the system.

3.3.5 SMAPE communication and coordination

The SMAPE coordination and communication is based on the blackboard and on direct messaging. The blackboard enables the communication among user agents, which access the blackboard to read the needed passive concept instances for their tasks. These instances are stored in the agent's level or a level below. If the requested instances are not in the blackboard, the agent has to wait until they are available. So the communication among agents is indirect and asynchronous and it provides flexibility when new agents have to be added to the system.

Direct messaging is only available for the agents-BCA communication. An agent messages the BCA when it needs some unavailable information. When the information is ready, the BCA answers the agent request with a replay message. It uses the KQML (Knowledge Query and Manipulation Language) protocol, KIF (Knowledge Interchange Format) syntax and the semantic defined by O_{SP} . The only KQML considered performatives are Subscribe, Tell and Ask.

4 CONCLUSIONS AND FUTURE WORK

In this paper, it is proposed the SMAPE MAS that allows the shared creation and design of the SP process, its execution for obtaining the strategic plan and its follow-up. SMAPE is a starting point for the definition of new models to formalize and implement other organizational processes.

One of the main contributions is the formalization using an ontology that demonstrates its suitability to formalize complex organizational process. Moreover, the ontology is the basis of an MAS that allows the design, execution and the follow-up of the organizational process. The MAS and, particularly the blackboard, is the framework that allows the collection, management and dissemination of the information and knowledge. The special structure of the blackboard, based on layers and levels, enables an efficient management of the information so that it can be stored and reused to generate new knowledge and intelligence and to reach certain automation. In fact, the historical layer is the basis of the further development of intelligent agents.

Although the model is developed for a concrete organizational process, the SP process, it can be easily generalized to other processes with similar features. The future work is focused on two facets: the implementation of SMAPE in a real organization and the application of the model to other organizational processes. In fact, some preliminary results of the implementation of SMAPE have already been achieved, and they demonstrate the suitability of the model to automate some important procedures of the SP process.

REFERENCES

- [1] Zara. O., *Le management de l'intelligence collective: vers une nouvelle gouvernance*, 2nd édn., actualisée et augm, M21 Editions: Paris, 2008.
- [2] Cox, M.Z., Daspit, J., McLaughlin, E. & Jones, R.J., Strategic management: is it an academic discipline? *Journal of Business Strategies*, **29**(1), pp. 25–42, 2012.
- [3] Monticolo, D., Mihaita, S., Darwich, H. & Hilaire, V., An agent-based system to build project memories during engineering projects. *Knowledge-Based Systems*, **68**, pp. 88–102, 2014. <http://dx.doi.org/10.1016/j.knsys.2013.12.022>

- [4] Maruta, R., The creation and management of organizational knowledge. *Knowledge-Based Systems*, **67**, pp. 26–34, 2014.
<http://dx.doi.org/10.1016/j.knsys.2014.06.012>
- [5] Nonaka, I. & Takeuchi, H., *La organización creadora del conocimiento: Cómo las compañías japonesas crean la dinámica de la innovación*, Oxford University Press: Mexico, 1999.
- [6] Riaño, D., Moreno, A., Isern, D., Bocio, J., Sánchez, D. & Jiménez, L., Knowledge exploitation from the web. *Practical Aspects of Knowledge Management*, Springer Berlin Heidelberg, vol. 3336, pp. 175–185, 2004.
- [7] Howson, C., *Successful Business Intelligence: Unlock the Value of BI & Big Data*, 2nd edn., McGraw-Hill Education: New York, 2014.
- [8] Prescott, J.E. & Miller, S.M. (eds.), *Proven Strategies in Competitive Intelligence: Lessons from the Trenches*, Wiley: New York, 2001.
- [9] Ferrara, E., De Meo, P., Fiumara, G. & Baumgartner, R., Web data extraction, applications and techniques: a survey. *Knowledge-Based Systems*, **70**, pp. 301–323, 2014.
<http://dx.doi.org/10.1016/j.knsys.2014.07.007>
- [10] Baumgartner, R., Gottlob, G. & Herzog, M., Scalable web data extraction for online market intelligence. *Proceedings of the VLDB Endowment*, **2**(2), pp. 1512–1523, 2009.
<http://dx.doi.org/10.14778/1687553.1687580>
- [11] Sánchez Torres, J.M. & Palop, F., *Herramientas de Software especializadas para Vigilancia Tecnológica e Inteligencia Competitiva*, IDICT, 2006.
- [12] Bittner, E.A.C. & Leimeister, J.M., Creating shared understanding in heterogeneous work groups: why it matters and how to achieve it. *Management Information Systems*, **31**(1), pp. 111–144, 2014.
<http://dx.doi.org/10.2753/MIS0742-1222310106>
- [13] Kotler, P., *Marketing Management: Analysis, Planning, Implementation, and Control*, 8th edn., Prentice Hall: Englewood Cliffs, N.J, 1994.
- [14] Hill, C.W.L. & Jones, G.R., *Strategic Management: An Integrated Approach*, 10th edn., South-Western, Cengage Learning: Mason, OH, 2013.
- [15] Wooldridge, M., Jennings, N.R. & Kinny, D., The gaia methodology for agent-oriented analysis and design. *Autonomous Agents and Multi-Agent Systems*, **3**(3), pp. 285–312, 2000.
<http://dx.doi.org/10.1023/A:1010071910869>
- [16] Gruber, T.R., A translation approach to portable ontology specifications. *Knowledge Acquisition*, **5**(2), pp. 199–220, 1993.
<http://dx.doi.org/10.1006/knac.1993.1008>
- [17] Orwig, R., Chen, H., Vogel, D. & Nunamaker, J.F., A multi-agent view of strategic planning using group support systems and artificial intelligence. *Group Decision and Negotiation*, **6**(1), pp. 37–59, 1997.
<http://dx.doi.org/10.1023/A:1008636524765>
- [18] Pinson, S.D., Louçã, J.A. & Moraitis, P., A distributed decision support system for strategic planning. *Decision Support Systems*, **20**(1), pp. 35–51, 1997.
[http://dx.doi.org/10.1016/S0167-9236\(96\)00074-7](http://dx.doi.org/10.1016/S0167-9236(96)00074-7)
- [19] Corkill, D.D., Collaborating software: blackboard and multi-agent systems & the future. *In Proceedings of the International Lisp Conference*, New York, 2003.
- [20] Liu, Q., Sun, S.X., Wang, H. & Zhao, J., A multi-agent based system for e-procurement exception management. *Knowledge-Based Systems*, **24**(1), pp. 49–57, 2011.
<http://dx.doi.org/10.1016/j.knsys.2010.07.004>

- [21] Paradies, S., Zillner, S. & Skubacz, M., Towards collaborative strategy content management using ontologies. *Workshop on Collaborative Construction, Management and Linking of Structured Knowledge*, 2009.
- [22] Paradies, S., An approach to support strategic planning by ontological structures. *Fourth International Conference on Research Challenges in Information Science*, pp. 673–680, 2010. <http://dx.doi.org/10.1109/rcis.2010.5507269>
- [23] Aguilar, J., Rivas, F. & Cerrada, M., Multiagents systems for planning and management of the production factors in automation. *Ciencia e Ingeniería*, **31**(1), pp. 13–24, 2010.
- [24] Llorens-Largo, F., Strategic Plan of the University of Alicante, 2007.
- [25] Noy, N.F. & McGuinness, D.L., Ontology development 101: a guide to creating your first ontology. Stanford knowledge systems laboratory technical report KSL-01-05, 2001.
- [26] Dalmau-Espert, J.L., Llorens-Largo, F. & Molina-Carmona, R., An ontology for formalizing and automating the strategic planning process. *7th International Conference on Information, Process and Knowledge Management*, 2015.
- [27] Dalmau-Espert, J.L., Llorens-Largo, F. & Molina-Carmona, R., A multi-agent strategic planning system based on blackboard. *9th International Symposium on Intelligent Distributed Computing*, 2015.